

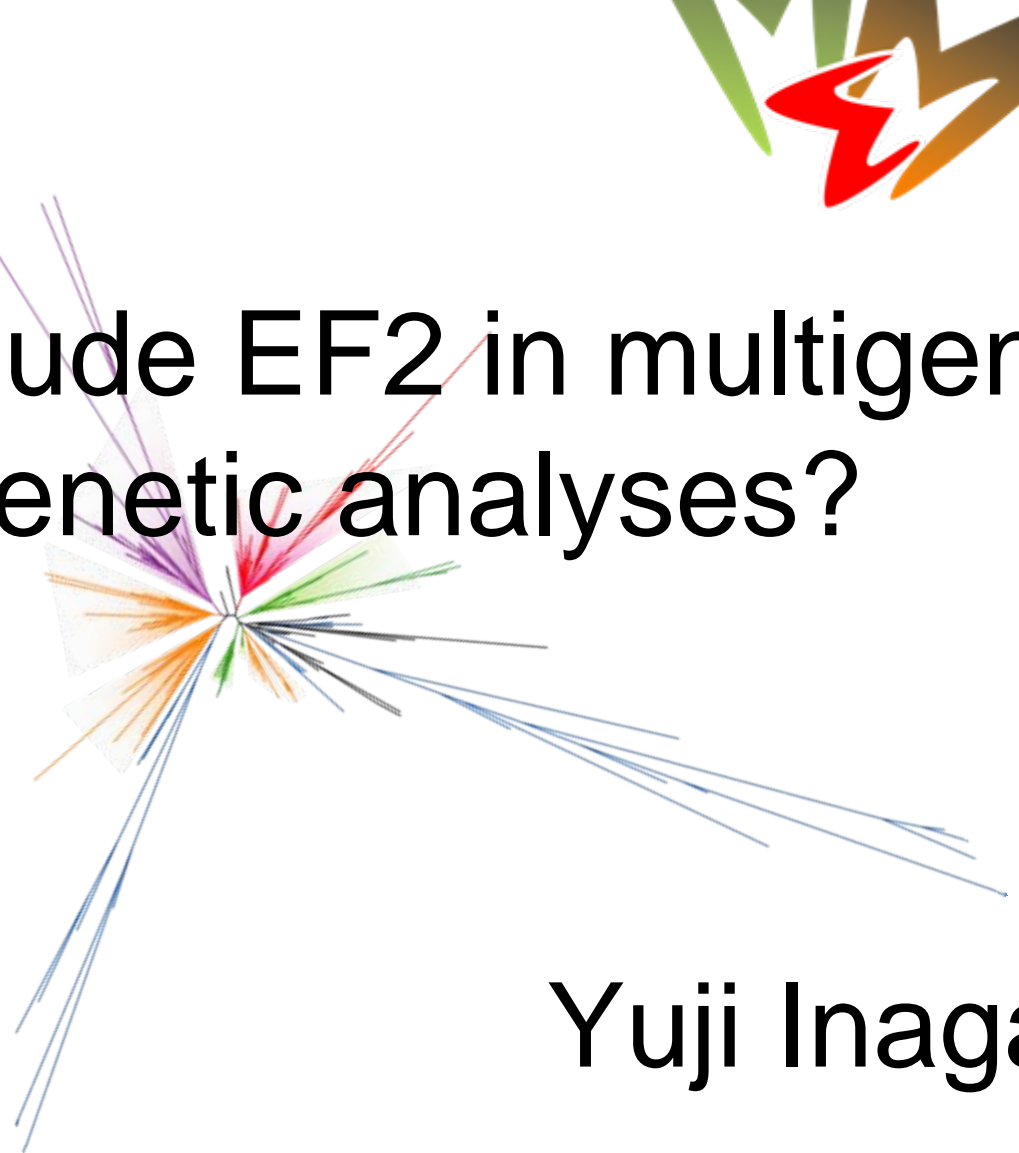

Can we include EF2 in multigene phylogenetic analyses?



Yuji Inagaki

- Catalyzes translocation of aa-tRNA from A site to P site in ribosomes
 - Highly conserved
- EF2 is a major “maker”
 - Monophyly of red algae and green plants (Moreira, Le Guyader & Philippe 2000)
 - Stiller, Riley & Hall. (2001) suggested that red and green genes were recombined
- Here we tested
 - Multi-gene data w/ and w/o EF2
 - “Recombination” hypothesis by Stiller et al.

- ML method under the unlinked WAG + Γ model
 - Among-site rate variation
 - Variation of evolutionary patterns across genes
- 24 nuclear-encoded protein genes
 - EF-1 α , EF2, IleRS, ValRS, RPS14, RPS15a, RPL5, RPL8, RPL10a, RPB1, cytosolic-Hsp70, ER-Hsp70, mitochondrial-Hsp70, cytosolic-Hsp90, Cpn60, CCT α , CCT δ , CCT γ , CCT ζ , Actin, α -Tubulin (Tba), β -Tubulin (Tbb), vATPA, vATPB
- >10,000 aa positions

- Assumed the monophyly of the 7 groups
 - Opisthokonts
 - Amoebozoa
 - Green plants
 - Red algae
 - Euglenozoa + Heterolobosea
 - Alveolates + stramenopiles
 - Diplomonads + parabasalids
- Exhaustively searched for the ML tree from 945 test trees
- Bootstrap analysis

- Calculated the InL of 945 trees for each gene
 - Parameters optimized for each gene

	T_1	T_2	T_3	...	T_N	...	T_{944}	T_{945}
Data 1	InL	InL	InL	...	InL	...	InL	InL
Data 2	InL	InL	InL	...	InL	...	InL	InL
Data 3	InL	InL	InL	...	InL	...	InL	InL
⋮	⋮	⋮	⋮		⋮		⋮	⋮
Data 10	InL	InL	InL	...	InL	...	InL	InL
⋮	⋮	⋮	⋮		⋮		⋮	⋮
Data 23	InL	InL	InL	...	InL	...	InL	InL
Data 24	InL	InL	InL	...	InL	...	InL	InL
Total	InL_1	InL_2	InL_3	...	InL_N	...	InL_{944}	InL_{945}

- Calculated InL by a *modified* Tree-Puzzle

Sequential

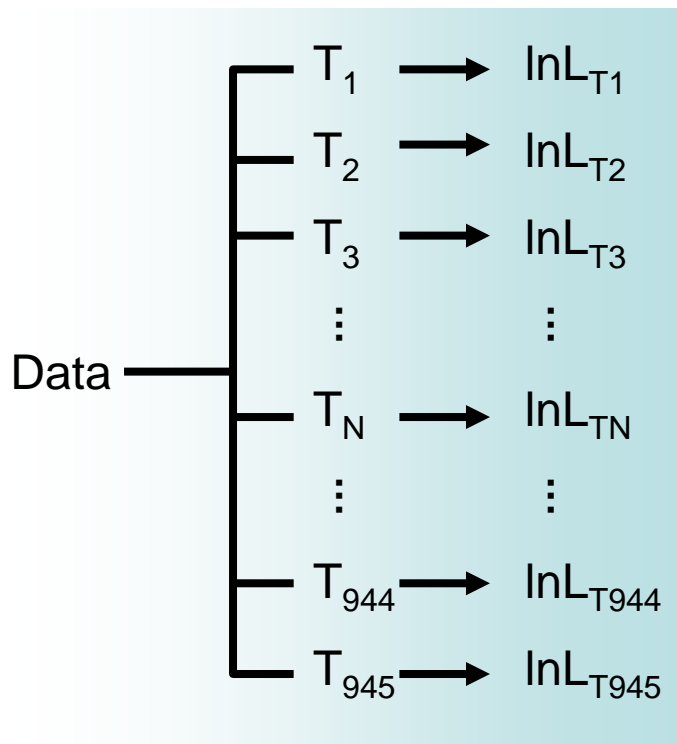

Parallel

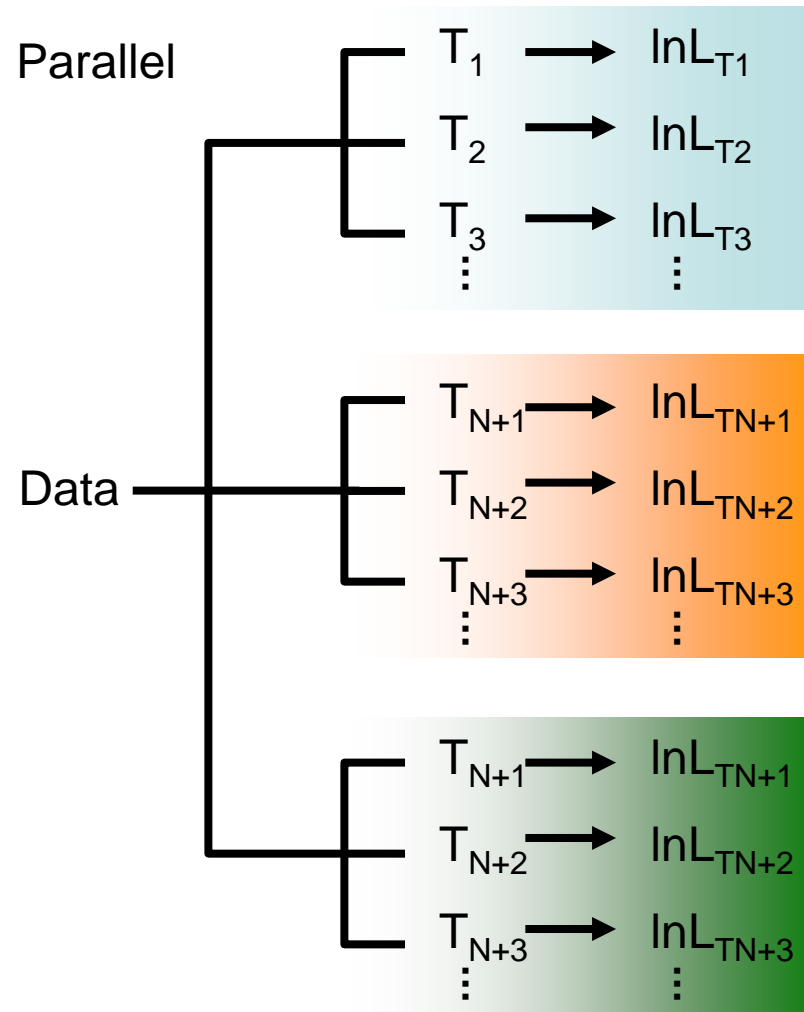

- Are strong supports true?
 - EF2 prefers R+G
- Are the signals uniform?
 - Single-gene JK
 - More systematic way to compare signal in each gene
 - By using P values of SH tests

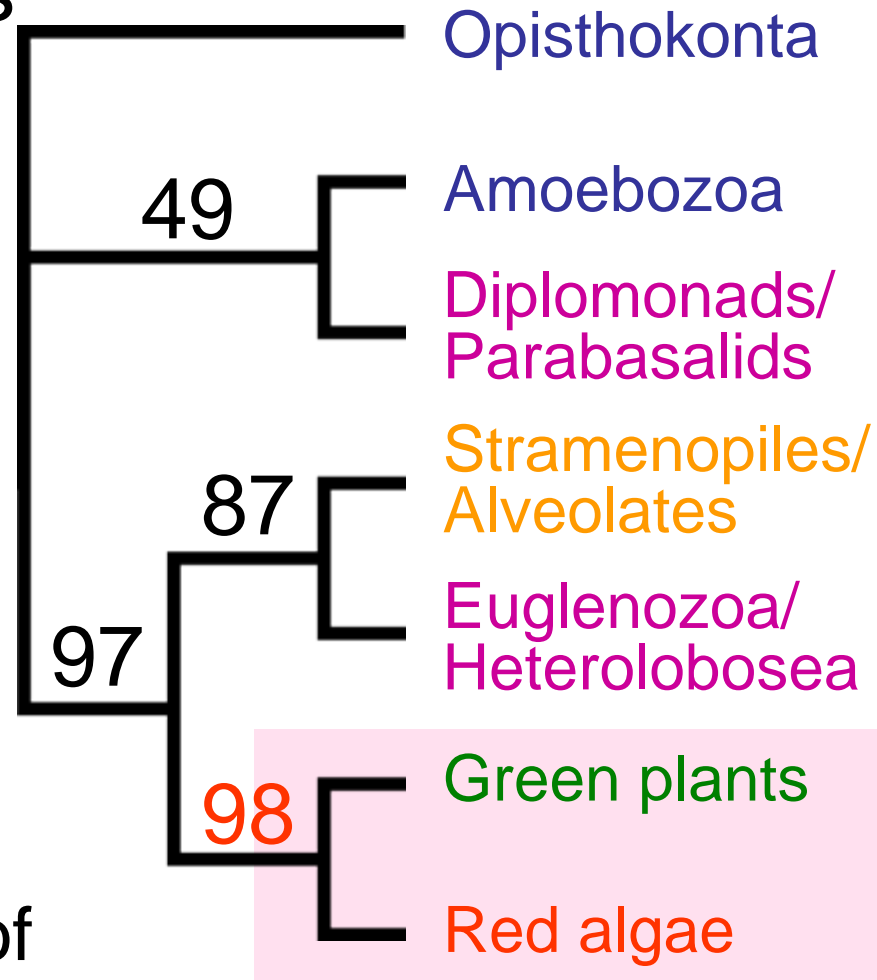

- “Gene-specific signal” was represented by P values of SH tests
 - P values are color-coded
 - EF2: 109 trees passed
 - All trees w/ “R+G” passed

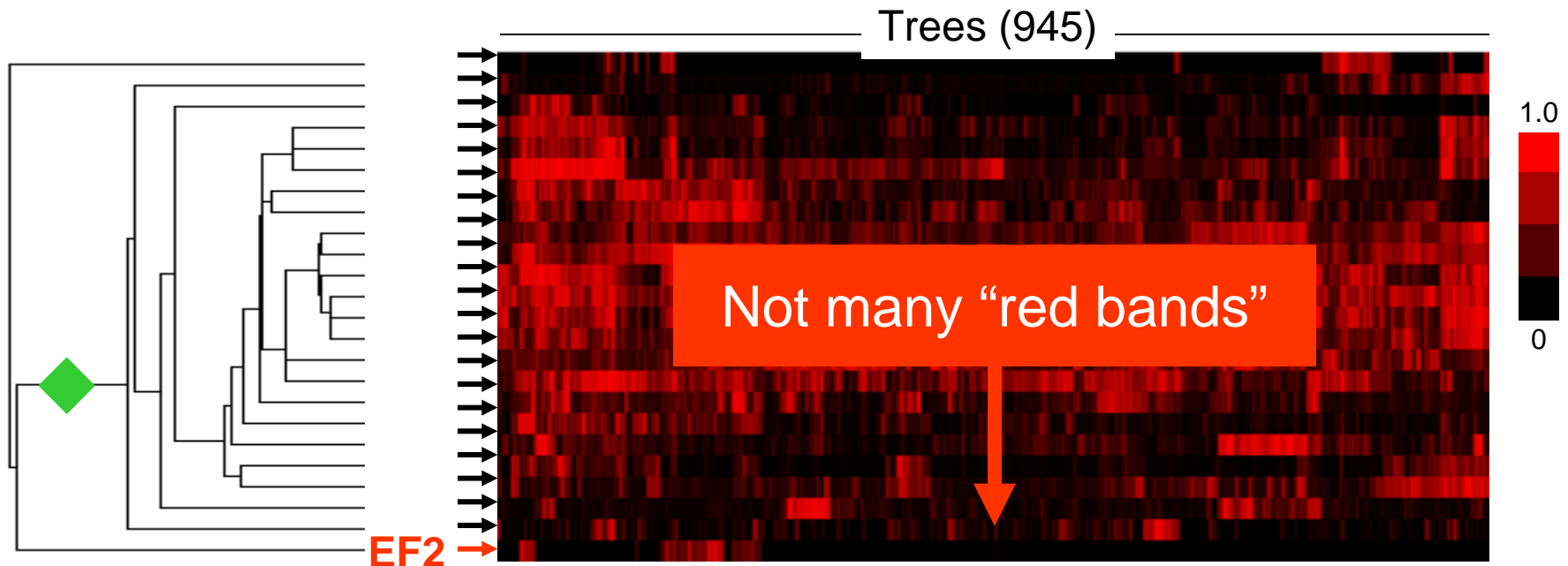

- R+G recovered
 - BP decreased
 - Other genes also prefer R+G
- EF2 signal
 - Is not incongruent with those of other genes
- OK to use EF2
- How about the GR?

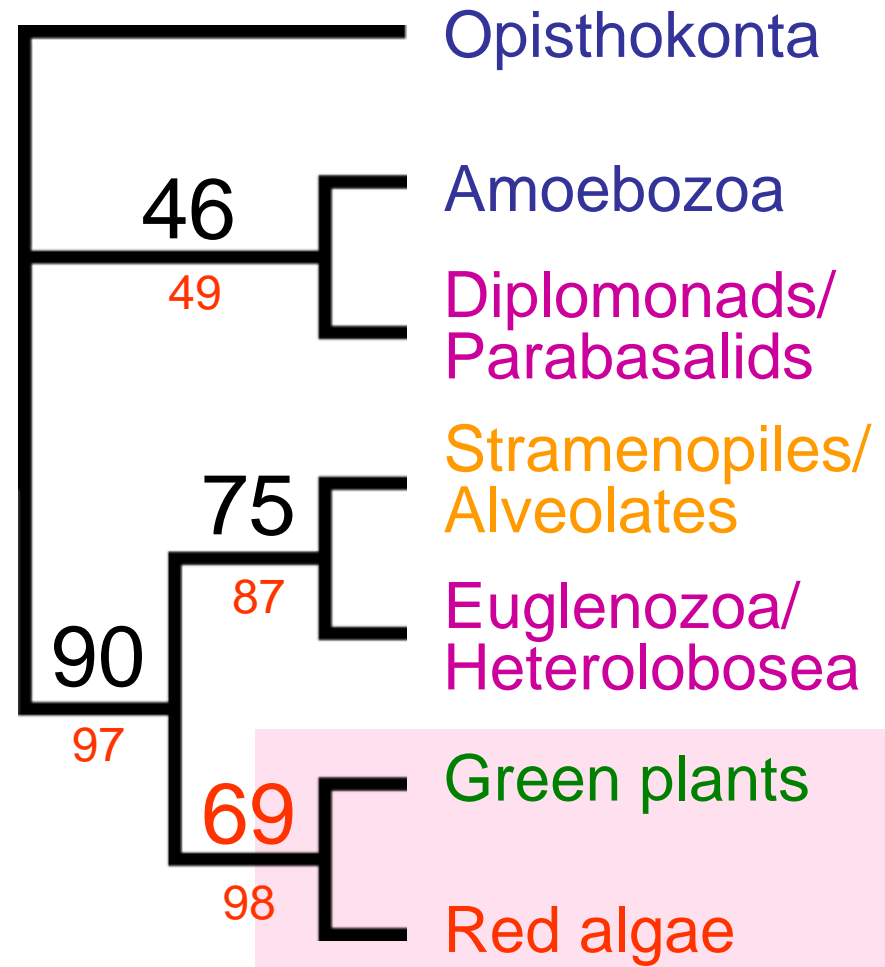

- Stiller, Riley & Hall. JME 2001 52:527-39
 - Red & Green EF2 were recombined
 - EF2 phylogeny: Artifact from the GR signal
- Test the “GR” hypothesis
 - R+G tree: the ML tree
 - RxG tree: the best tree with no R+G clade
- Calculated site-InLs over the two trees
 - Sites that prefer the R+G tree over the other
 - Do the R+G sites pack in a short region?

EF2: gene recombination between Red & Green?

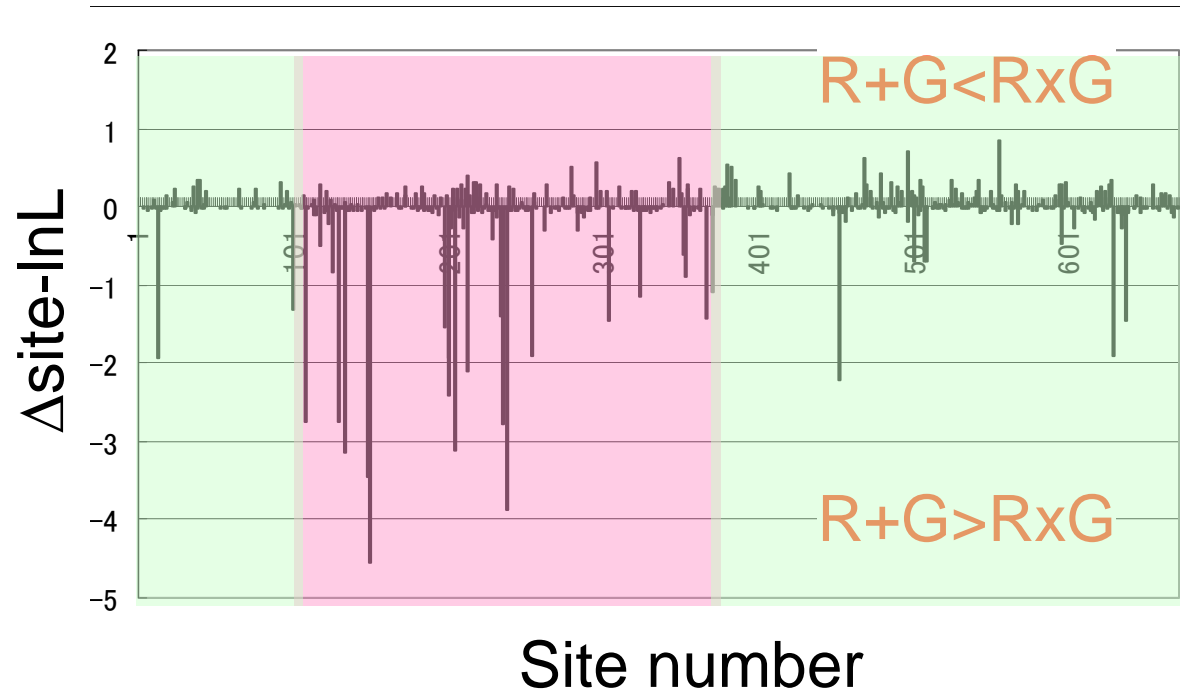

- R+G signal locates the non-pink area
- The ML tree of the green area: no R+G clade
 - A R+G tree: The 2nd best ($\Delta \ln L = 0.2$; $P = 0.828$)
- No strong reason to invoke the GR proposed